

Technical Information

No. FO 4987

Edition: 08/05 - subject to change

Substitutes: Edition 12/00

Status: valid

Xenon Short Arc Lamp

XBO[®] 450 W/1

■ Product description

The OSRAM XBO[®] 450 W/1 is a DC-operated lamp that is especially suited for applications requiring excellent arc stability and a high luminance.

■ Technical data

Order reference	XBO [®] 450 W/1	
Rated lamp wattage	W	450
Rated lamp voltage	V	17
Rated lamp current (=)	A	25
Current control range	A	17 - 30
Ignition voltage	kV _s	40
Min. open circuit voltage for cold / hot ignition	V	60 / 70
Luminous flux	lm	13,000
Luminous intensity	cd	1,300
Average luminance	cd/cm ²	45,000
Luminous area w x h *)	mm	0.7 x 2.2
Electrode gap e (cold)	mm	2.8
Lamp length (overall) l ₁	mm	max. 260
Lamp length l ₂	mm	max. 212
LCL a	mm	95.5
Bulb diameter d	mm	29
Average service life	h	1000
Warranty	h	800
Base	Cathode	SFa 20-10
	Anode	SFa 20-8

*) w = luminance half width value; h = height of luminance area (corresponds to electrode gap, hot)

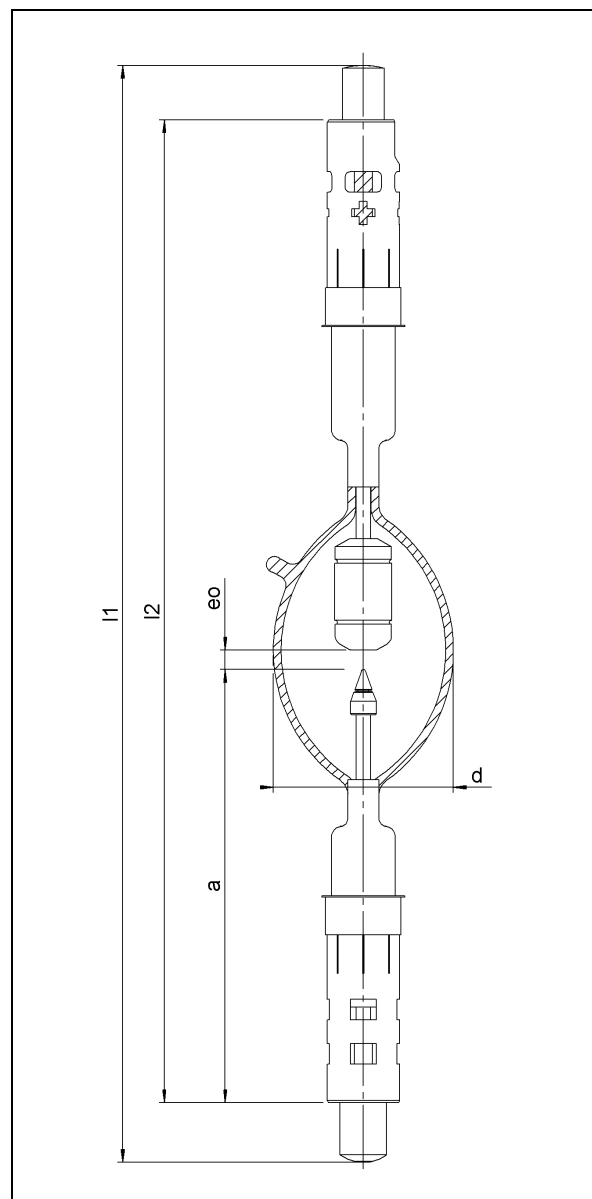

■ Lamp operation

Maximum permissible base temperature	230 °C
Cooling	forced cooling / fan
Min. air flow velocity around discharge vessel	3 m/s
Magnetic arc stabilization	no
Burning position	s 100 (vertical ± 100° ; anode up)